

# 3

## LAUNCH DESIGNS



Natural Surfaces

Geotextile Mats

Concrete Mats

Concrete Ramps

Wooden Stairs

Concrete Stairs

Docks / Piers

Cantilevers

Floating

Elevated Walkways

Portages

Many launch types are available to meet the needs of various environments. This section can help you choose the appropriate design and construction method for your site.



## List of Figures, Tables and Case Studies

127	Figure 3-1	Concrete Mats – Variations and Specifications
128	Figure 3-2	Concrete Mats – Variations and Specifications 2
146	Figure 3-3	Wooden Stairs – Materials
148	Figure 3-4	Wooden Stairs – Variations and Specifications
153	Figure 3-5	Wooden Stairs – White Rock Park Detailed Profile
154	Figure 3-6	Wooden Stairs – White Rock Park Landscape Profile
157	Figure 3-7	Wooden Stairs – Fisherman’s Bridge
170	Figure 3-8	Concrete Stairs – White Rock Park Side Profile
171	Figure 3-9	Concrete Stairs – White Rock Park Bird’s Eye View
172	Figure 3-10	Concrete Stairs – White Rock Park Detail of Grab Rail
173	Figure 3-11	Concrete Stairs – White Rock Park Canoe Launch Channel
184	Figure 3-12	Cantilevers – Materials
187	Figure 3-13	Cantilevers – MN Division of State Parks: Bird’s Eye View
188	Figure 3-14	Cantilevers – MN Division of State Parks: Side Profile
189	Figure 3-15	Cantilevers – MN Division of State Parks: Front Profile
207	Figure 3-16	Floating – Annsville Creek Launch: Bird’s Eye View
208	Figure 3-17	Floating – Annsville Creek Launch: Profile View





# List of Figures, Tables, and Case Studies

121	Case Study 3-1	Geotextile Mats – Deal Island WMA, St. Peters, MD
131	Case Study 3-2	Concrete Mats – York Bridge, Missouri River, MT
151	Case Study 3-3	Wooden Stairs – Jump Rock Park Launch Site
152	Case Study 3-4	Wooden Stairs – Concept Drawings for White Rock Park La Grange, TX
155	Case Study 3-5	Wooden Stairs – Fisherman’s Bridge
165	Case Study 3-6	Concrete Stairs – Confluence Park, South Platte River, Denver, CO
169	Case Study 3-7	Concrete Stairs – White Rock Park, Colorado River, La Grange, TX
201	Case Study 3-8	Floating Launch Design – Janes Island Kayak Dock
205	Case Study 3-9	Annsville Creek Paddlesport Center, Hudson River Watertrail Case Study
213	Case Study 3-10	Bladensburg Waterfront Accessible Launch Example
228	Case Study 3-11	Portages – Pejepscot River Access, Androscoggin River, Libson Falls-Brunswick, ME
118	Table 3-1	Geotextile Mats Materials – Vendors
126	Table 3-2	Concrete Mats Materials – Vendors
192	Table 3-3	Floating Launch Design Materials – Vendors





## Launch Design Categories

### Ramps

Perfect for gradually sloped banks. Various materials are used depending on the desired or necessary characteristics of your site.

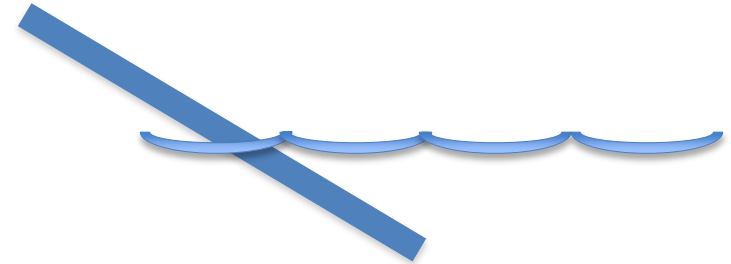

### Stairs

On sites where the banks are too steep to access by a ramp, stairs are an appropriate launch option.



### Elevated

Elevated launches can be used to bypass environmentally sensitive areas or areas of unstable ground. They are an appropriate choice for bulk-head banks as well.

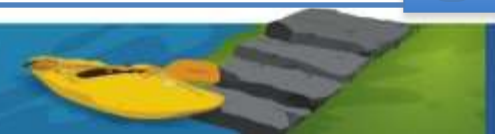



## Docks / Piers (Floating or Fixed)

### Docks / Piers

A pier or dock can be used independently as a launch or in combination with other structures. They are able to span marshes or shallow areas to enable launching in water of sufficient depth.



### Cantilevers

Cantilever launches extend out over the water from the shore, sometimes appearing to float on the water.



### Floating

Floating launches are structures that provide access while floating on the water. Typically composed of a deck, frame, and floats, they are anchored to the shore.





## Docks / Piers

- Pier structures can be used independently as launches or in combination with other structures. They can span marshes or shallow areas to enable launching in water of sufficient depth.
- In some cases, “approach pads” or walkway structures are designed to enable access to the launch itself. Structures are composed of a deck and frame, which stand above water level at all times, and are supported by piers. While [piles](#) can be used in any depth of water, pipes rest on supports (usually concrete pads) and are not suitable for deep water.

Materials

Variations and Specifications

Advantages / Disadvantages

Photo Examples

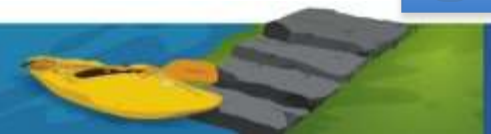



## Docks / Piers: Materials

- Decking is frequently made of wood, concrete, or wood-alternative materials
- Piles are usually made of treated timber, steel pipes, or concrete
- Pipe with diameters 1 1/2" and 3" is often used and preferable



Kayak launch from wooden dock



Treated timber piles on wooden dock





# Environmental Impact of Pipe and Pile Installation

- Pier design and construction can create negative environmental impacts, as well as health ramifications for those involved in their construction. Piling methods should be researched for those involved in their construction. [Wetland Trail Design and Construction](#), produced by the US Forest Service, is a resource that discusses [pile](#) installations in depth.
- While there is limited research available on the environmental impacts of piling, some methods clearly cause less disruption to sediments and vegetation than others. The process of “diving,” for example, is significantly less disruptive than “jetting,” which uses high-pressure hoses. Disturbances to sediments in sandy areas can be greatly reduced when low-pressure pumps are used to create an initial hole and sharpened piles are installed with a drop hammer.







## Environmental Impact of Wood Preservatives

- According to some studies, the greatest likelihood of water contamination from a launch construction occurs from preservatives that are applied to pilings or floats in locations that come into regular contact with water. Many states have banned the use of oil-based preservatives containing creosote (CRT) or pentachlorophenol (PCP) in aquatic areas due to their demonstrated toxic effects from leaching, since soluble components separate and leak into the water.
- The US Government has banned the sale and use of what used to be the most common material used in pressure-treated wood used for pilings and decking, chromated copper arsenate (CCA).
- ACQ, an alternative to CCA, is a water-based wood preservative that prevents decay from fungi and insects (i.e., it is a fungicide and insecticide). There are currently four AWPA standardized ACQ formulations, ACQ Types A, B, C, and D. The different formulations allow flexibility in achieving compatibility with different wood species and end use applications.
- Water-based preservatives like ACQ leave a dry, paintable surface. ACQ is registered for use on: lumber, timbers, landscape ties, fence posts, building and utility poles, land, freshwater and marine pilings, sea walls, decking, wood shingles, and other wood structures.
- More information on ACQ can be found here: [EPA: Pesticides Regulation](#)

[Best Management Practices for Treated Wood in Aquatic and Wetland Environments](#)





## Docks / Piers: Variations and Specifications

- Water level should be lower than the level of the deck at all times
- Pier legs need cross bracing and bracketing to the frames for reinforcement and stabilization, as seen in the photo to the right.





# Docks / Piers: Advantages and Disadvantages

## Advantages

- Effective in areas of strong current
- Stable surface for launching
- Good choice for providing access to paddlers with disabilities; handrails or step-downs may be easily added
- Usually requires shoreline alteration
- Relatively inexpensive
- Easily visible from rivers
- (Pipe docks) Can be easily adjusted or removed

## Disadvantages

- Does not accommodate extreme variations in water level
- ([Piles](#)) Can have damaging environmental impacts, such as altering currents if they disrupt flows or sediments
- (Piles made of treated wood) Can contaminate water





# Docks / Piers: Photo 1





# Docks / Piers: Photo 2





## Cantilevers

Cantilever launches extend out over the water from the shore, sometimes appearing to float on the water, as seen in the image below. Their main supports on shore often include anchors that are partially submerged in water.



Materials

Variations and Specifications

Advantages / Disadvantages

Plans





# Cantilevers: Materials

Frequently made of wood, with steel or wood supports

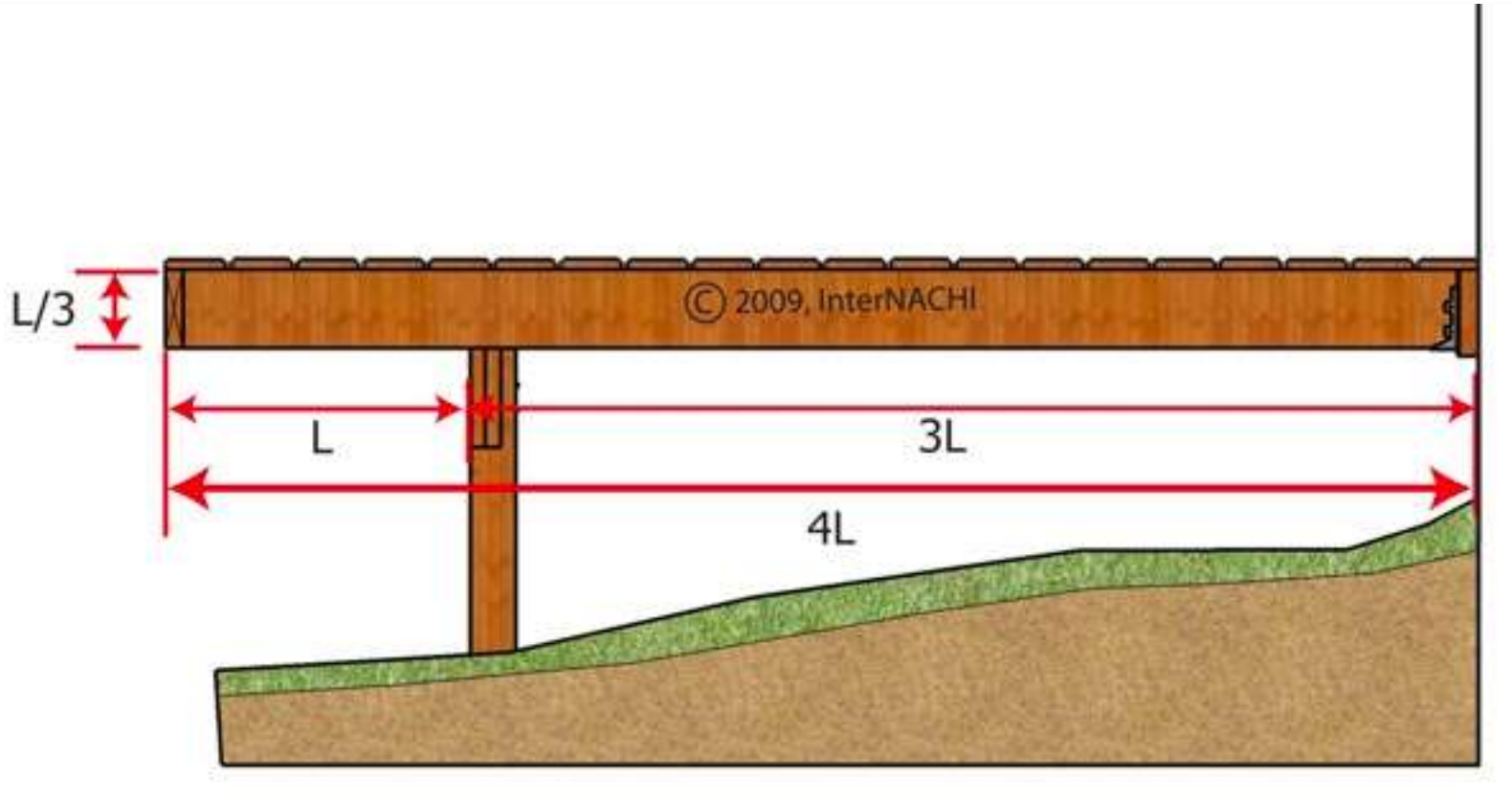



## Cantilevers: Variations and Specifications

- Can be used as a launch on its own or connected to other launch structures.
- Anchor and frame must be built to accommodate weights of the launch, boats, and paddlers.
- Engineers should be consulted to determine if a cantilever structure is the best option given the launch's level of use.



A cantilevered dock on the Wisconsin River







# Cantilevers: Advantages and Disadvantages

## Advantages

- Can provide access in environmentally sensitive areas while protecting riparian habitat and shoreline vegetation
- Suitable in a wide range of locations and shoreline configurations
- Can have removable deck sections or posts
- Relatively inexpensive

## Disadvantages

- Load capacity is limited; cannot support excessive weight
- Treated wood can be hazardous to the environment
- May not last as long as a fixed or floating launch due to support and weight limitations





## Cantilevers Case Study: Minnesota Division of State Parks 1

This cantilever launch is composed of deck sections and posts that can be removed seasonally. 2 ½" footing pipes with cross bolts in place are installed into the shore bottom until they are firm (18" to 24" below the water surface). 2" pipes are installed through metal deck brackets and into pipes, capped on upper threaded ends. Deck is leveled by set screws in brackets. Dock can be unbolted when screws are loosened and 2" pipes are removed. Dock sections can be removed, leaving the footing pipes in place.

### Bird's Eye View

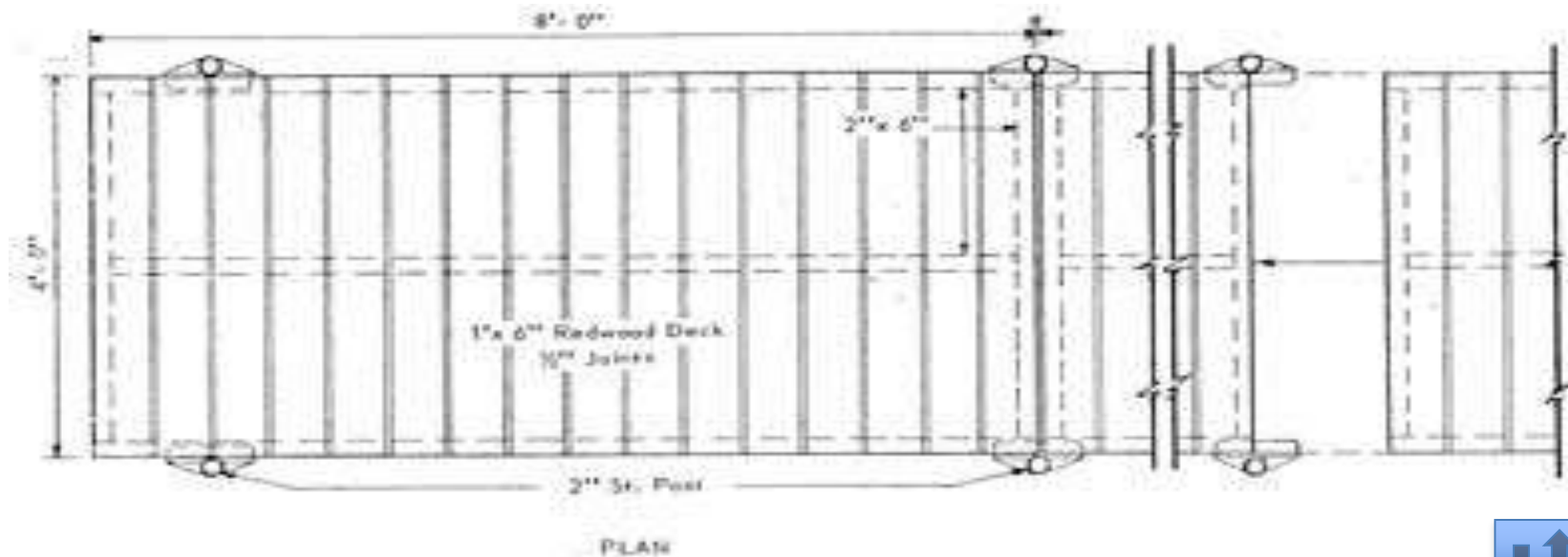



# Cantilevers Case Study: Minnesota Division of State Parks 2

Side Profile

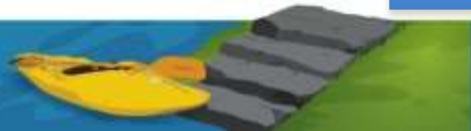
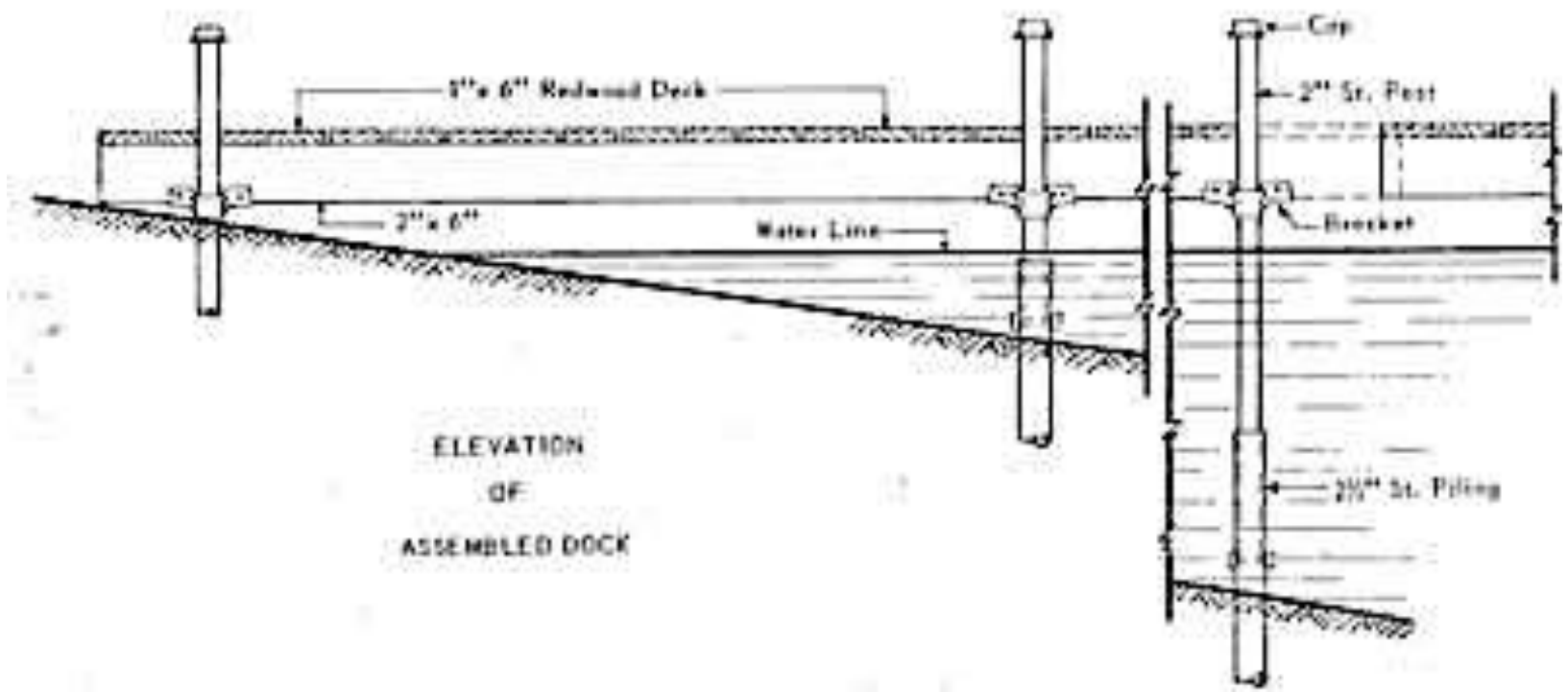



# Cantilevers Case Study: Minnesota Division of State Parks 3

Front Profile

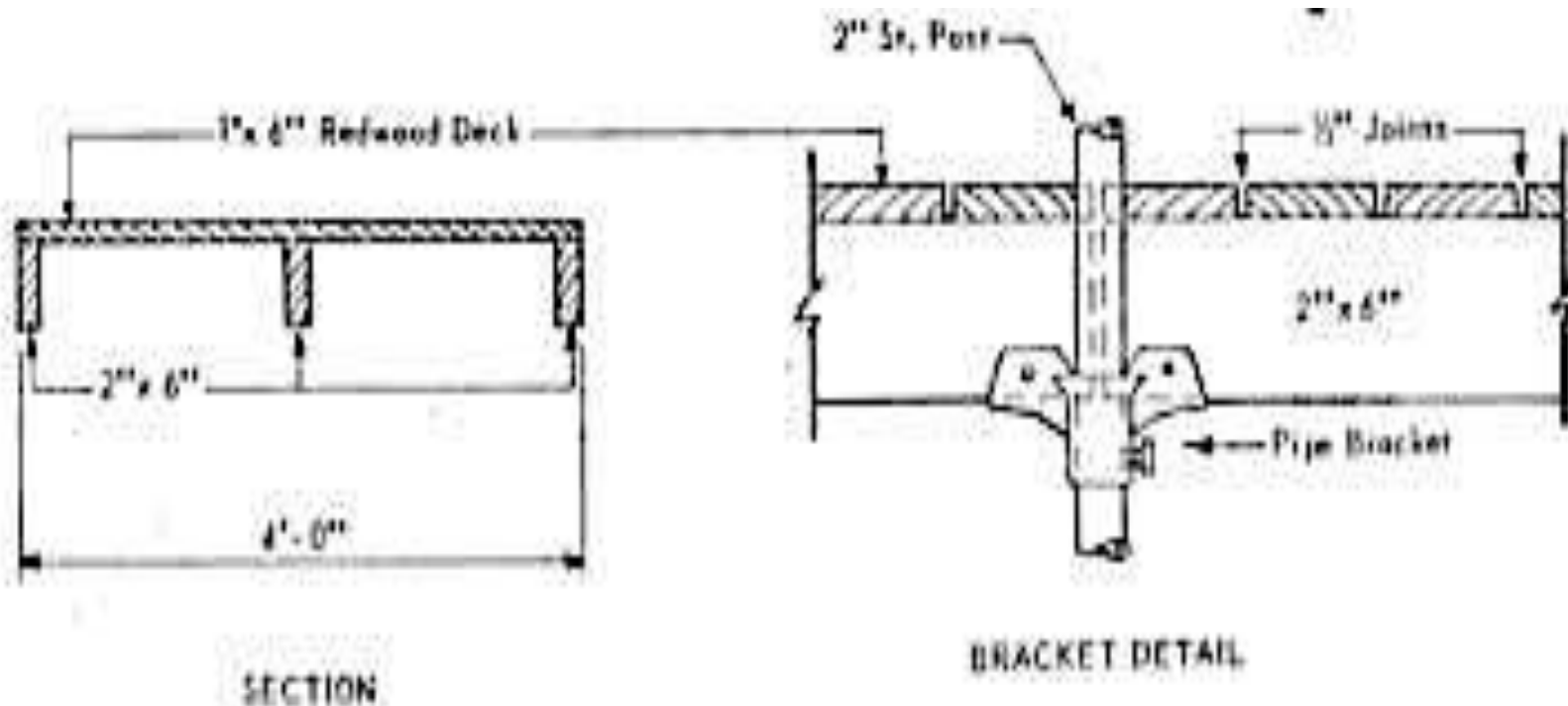



# Floating

Floating launches are structures that are not built into the bottom of the water body. Typically composed of a deck, frame, and floats, they are anchored to the shore. Paddlers launch from the deck, which is supported by the frame, while the floats beneath the frame provide buoyancy. Anchoring devices help to stabilize the launch and protect it from the elements. [Pile guides](#) are often used, allowing launches to adjust to changing water levels while keeping their decks horizontal and steady. When floating launches attach to connecting structures with varying heights (e.g., [gangways](#)), pile guides can help to maintain a relatively small cross slope, making launches more likely to be accessible to paddlers with disabilities.

Floating launches are most effective when used on water with little debris and minimal exposure to strong currents or waves. In general, they can withstand flow rates up to 0.25 feet per second. Floating launches should be removed and secured during flooding or high flow events, and unless they are specifically designed to endure ice formation, they should be removed before freezing occurs.

Materials

Variations and Specifications

Advantages / Disadvantages

Case Study





## Floating: Materials

Decks

Frames

Floats

### Concerns with Plastic and Wood Products

- A variety of materials can be used for the decks, frames, and floats that make up a floating launch. Consider the durability needs of your launch site when choosing your materials. Plastics are regularly used for this launch design and have various levels of durability.
- Treated wood is also commonly used for floating launches. Treated wood must be used with caution in regard to the environment and to the health of those involved in construction. While treated wood can last up to five times as long as untreated wood, there are risks involved with their preservatives and chemical treatments.



Pressure treated wood frame





## Floating: Materials

The following vendors carry floating launch products and supplies. This is not an exhaustive list and is meant as a sampling. It is also not an endorsement of these companies or their products.

Mod-U-Dock

Flotation Systems, Inc.®

JetDock

Connect-A-Dock

GatorDock™

Dock Floats Ltd.

Traveldock™

Tiger Docks

Alumidock®

CMI Waterfront™  
Solutions

ShoreMaster

Johnston's Docks





## Floating: Deck Materials

- Wood is simple and inexpensive to use; pine, redwood, cedar, and cypress are common choices, but they will not last very long unless treated with a preservative.
- Metal decking, such as aluminum, is used mainly for heavy-use launches that also serve motorized boats. Metal grating provides effective drainage and traction.
- Alternative materials include wood/plastic composites, vinyl, and various plastics made of recycled materials that are made to look like wood. These materials may be more expensive and require additional support devices, but are more resistant to damage and warping than wood, and require less maintenance.



**Galvanized steel frame floating dock with marine-grade PVC. No toxic chemicals are in this recyclable decking.**

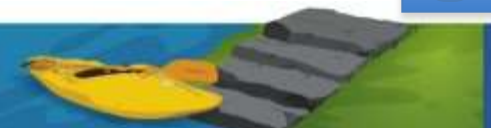





## Floating: Frame Materials

- Wood - Often used, but will last only 2 to 3 years if untreated
- Metal - Either lightweight aluminum or galvanized metal
- Plastic - Water resistant and will not degrade in water as rapidly as other materials
- Steel tubing - Used for floats and frames, and attaches to deck with brackets. Steel can be coated to increase durability.



**Aluminum framed floating dock with non-slip deck surface**

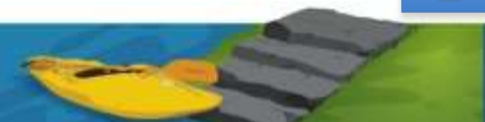



## Floating: Float Materials 1

- Polyethylene, the most frequently chosen plastic, can function as both a frame and float; they may have grooves and brackets that easily attach to shoreline structures or floats may have built-in [cleats](#), which facilitate anchoring.
- When expanded polystyrene foam (EPS) is used, the best choice is extruded closed cell because it has the strongest inner structure; it must be used with a protective covering to prevent damage from chemicals, water, and debris.
- Plastic float drums made of rotationally molded polyethylene are more durable than EPS and provide protection from impact damage, animals, and the effects ultraviolet (sun) light; these are most effective when filled with EPS, which act as shock-absorbers and protect drums, if damaged, from losing buoyancy.



This information is provided by the U.S. Forest Service publication entitled [Floating Trail Bridges and Docks](#)





## Floating: Float Materials 2

- Fiberglass float drums are not as strong as plastic float drums or as readily available, but they are lightweight and water-resistant. Fiberglass will degrade in sunlight over time more than most plastics.
- Foam-filled tires provide effective stabilization in areas with heavy debris or current; these can be made of recycled tires filled with EPS and capped with plywood. Commercial versions are available that are pre-made sealed and attached.
- Recycled 50-gallon cooking oil drums can also be used, but must be cleaned professionally to safeguard against contamination. Motor oil drums or any drums that have held noxious or hazardous materials should never be used.
- Concrete floats are sturdy and stable, but are also costly and heavy.
- High-density polyethylene (HDPE) can be used for both flotation and for framing, as seen in the image to the right.





## Floating: Variations and Specifications

- May be used in combination with bridges, [gangways](#), fixed piers, or [bulkheads](#) to enable paddlers to put-in at water of sufficient depth. These structures may be attached with hinges and used across shallow areas to provide access to a floating dock; they should have slopes of less than 20 degrees (or no more than 8.33%) and should remain horizontal at high water levels. Equip with handrails to offer maximum stability for users.
- May be used in combination with elevated walkways or geotextile mats in environmentally sensitive areas, in order to prevent damage to riparian areas.
- May be used in combination with motorized boat ramps to enable hand-launching
- Needs a deck that rises at least 2 feet above water to enable safe access
- Should float on at least 3 feet of water
- Should not rest too high above the surface of the water, as this can make transitions from canoes and kayaks difficult





# Floating: Advantages

## Advantages

- Adjusts to fluctuating water levels – (it’s always the “right” height)
- Provides a sturdy surface, and a solution to unsafe conditions or inconvenient access
- Has few long-term environmental effects
- Is easily removable in inclement weather or heavy flows, and may therefore requires less maintenance
- Provides an alternative to gravel ramps that will erode in areas of stronger waves or currents
- Is easy to purchase and assemble; allows for flexibility in design
- When wet, is not as slippery as launches with sloped surfaces
- Is unlikely to scratch boats
- Keeps feet dry during cold weather paddling





## Floating: Disadvantages

### Disadvantages

- Not appropriate for all access locations. Use should be limited to areas where the minimum water depth is 3+ feet at all times, changes in water level are slow, and exposure to the elements is minimal.
- May not consistently be accessible to all, since slopes of connecting structures may alter with changing water levels. Locks and [piles](#) may be used to create a specific elevation and keep the cross slope to a minimum.
- The launch may be exposed to stronger currents than it can withstand and additional structure may be needed.
- The anchoring process must be carefully considered, as it must take into account particular climate and site conditions. When placing anchor piles, the combination of wind, wave, current, and impact forces should be accounted for.
- Not effective for use in areas where tidal fluctuations are rapid and extreme. Floats may be beached at low tide or floats can disrupt sediments as they rise with high tide.





# Floating Launch Design: Case Studies

Janes Island Kayak Dock, Dougherty Creek Canal,  
Janes Island State Park, Maryland

Annsville Creek Paddlesport Center, Hudson River Greenway Water Trail  
Hudson Highland State Park, New York

Bladensburg Waterfront Accessible Launch,  
The Maryland-National Capital Park and Planning Commission





# Floating Launch Design Case Study: Janes Island Kayak Dock

## Problem:

- Paddlers needed an alternative launch site at a busy marina. The existing concrete boat ramp was crowded with powerboat use and its slippery surface and steep incline made it hazardous for paddlers. Since the entire shoreline is bulk headed, there were no “soft landing” alternatives to provide paddlers with access to the water.

## Solution:

- Maryland Department of Natural Resources purchased a floating 8' x 20' dock designed specifically for canoes and kayaks that attaches to [bulkhead](#) pilings with metal rings. The new launch was placed outside the entrance to the marina basin so that paddlers do not have to cross incoming and outgoing boat traffic into the basin. Paddlers access the launch from a ladder, so it is not easily accessible to those with disabilities.







## Floating Launch Design Case Study: Janes Island Kayak Dock Specifications

### Deck:

2' x 6' with 3" x 6" side [stringers](#)

### Frame:

Wood, 2' x 6' cross stringers, ¼" steel brackets reinforce outside corners

### Floats:

Polyethylene shell filled with foam, 8" x 20" x 72" long





# Floating Launch Design Janes Island Kayak Dock Photo 1





# Floating Launch Design Janes Island Kayak Dock Photo 2





## Floating Launch Design Case Study: Annsville Creek

- Commercially manufactured floating launches may be used in combination with other structures, such as [gangways](#) or pier launches. Wholesalers sell floating launches built of pre-fabricated modular sections that can be connected together to adapt to site specifications.
- The following photos and designs portray access at Annsville Creek to the Hudson River Greenway Water Trail, a tidal river with water levels that may fluctuate 4 feet between tides.
- Several different structures are used at this site to accommodate paddlers at different water levels: a modular polyethylene floating launch connects to a wooden floating dock that is accessible from a concrete landing on the shore via two parallel aluminum gangways. The floating launch has four kayak slots or boat slides, where paddlers can easily transition into and out of the water. The entire launch configuration is accessible and is used to teach paddlers with disabilities, as well as to train instructors who teach paddlers with disabilities.





# Floating Launch Design Case Study: Annsville Creek Specifications

## Floating Launch:

22' wide x 30' long; structure made of 234 polyethylene polymodules.

## Wooden Floating Dock:

8' wide x 30' long, connects to floating launch and two transition plates.

## Transition Plates:

Two parallel aluminum [gangways](#), each 4' wide x 25' long at shoreline; extends into water 42" below shoreline level

## Reinforcements:

[Rip-rap](#) extends from edge of concrete landing across half of gangway length

- Total width of kayak slots = 16.67'
- Small, upright, inverted modules on outer edge of launch are vented to allow for adjustment.





# Floating Launch Design Case Study: Annsville Creek 1

Bird's Eye View

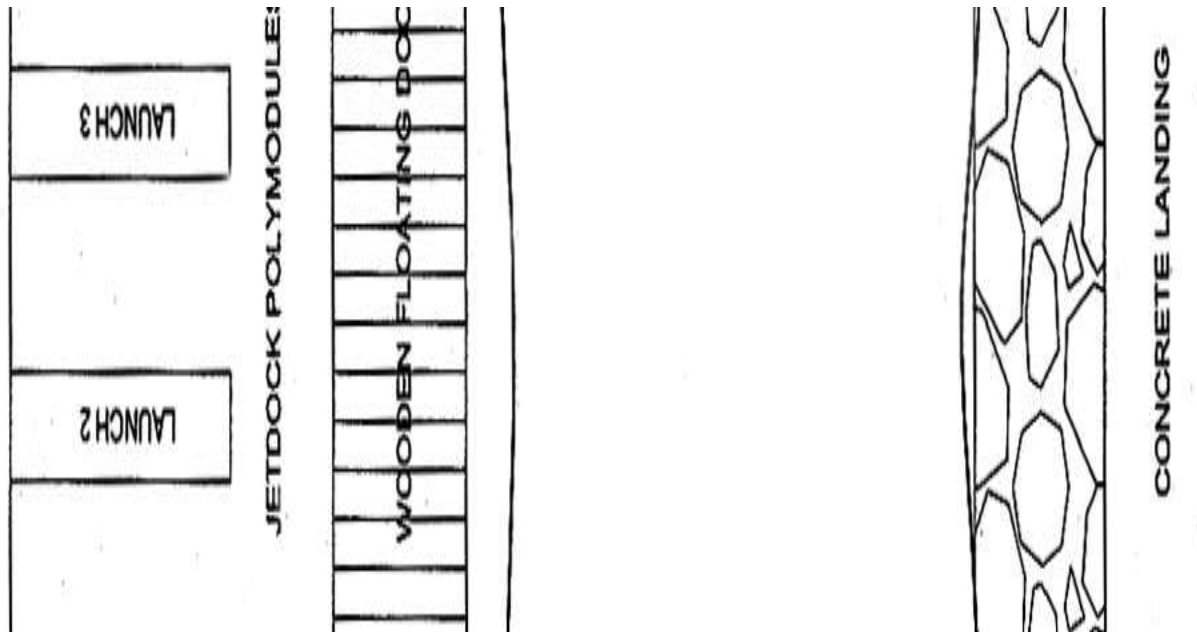



# Floating Launch Design Case Study: Annsville Creek 2

Profile View

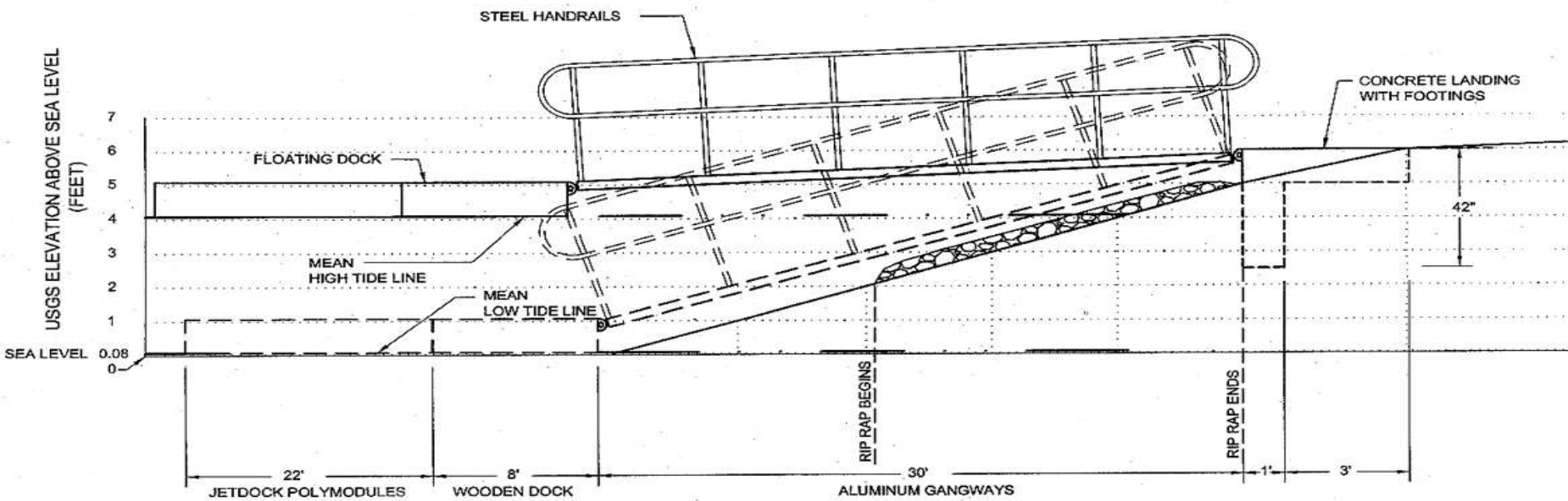

REVISED FLOATING DOCK ANCHORAGE SYSTEM





# Floating Launch Design: Annsville Creek Photo 1







# Floating Launch Design: Annsville Creek Photo 2





# Floating Launch Design: Annsville Creek Photo 3





# Floating Launch Design: Annsville Creek Photo 4





# Floating Launch Case Study: Bladensburg Waterfront Launch Photo 1





# Floating Launch Case Study: Bladensburg Waterfront Launch Photo 2





## Elevated Walkways and Portages

The main focus of this guide is launch development, but an important additional element of site design is creating appropriate pathways to launch sites.

Elevated Walkway Design



Portages





## Elevated Walkways

Elevated walkways are raised structures that allow paddlers to access launching areas without having direct contact with the ground. They are effective in minimizing potential impacts from recreational use on riparian habitats, fragile shorelines, or other environmentally sensitive areas. While providing a stable surface, elevated walkways can also prevent erosion, protect existing vegetation, and promote vegetation of damaged areas. Elevated walkways usually let light penetrate to the ground below so that vegetation beneath them receives the sunlight necessary for growth.



Materials

Variations and Specifications

Advantages / Disadvantages

Photo Examples





## Elevated Walkways: Materials

Typically constructed from expanded metal, aluminum, fiberglass, or wood. They are most effective when used with tripods or other above-ground supports. These can include posts that are driven into the bank; however, posts should not be installed too close to the edge of the bank, or they may contribute to erosion. If a ladder is used, it should have minimal contact with the bank or shoreline vegetation at all water levels. Shorter walkways are preferable so that wildlife may access water easily.







## Elevated Walkways: Variations and Specifications

Elevated walkways are versatile:

- They may be combined with other walkways or connecting structures to provide access to floating or other types of launches.
- They may be attached to stairs or ladders that lead to launch structures or rest on the bottom of a river or lake.
- They can be cantilevered over a river while supported by a tripod.

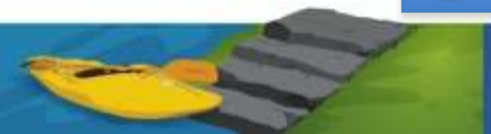



# Elevated Walkways: Advantages and Disadvantages

## Advantages

- Keeps people off vegetation
- Allows native vegetation to grow
- Provides access and directs people to recreational sites
- Protects investment - stream bank and restoration work
- Prevents trampling and erosion of vegetation
- Protects fish and wildlife habitat

## Disadvantages

- Moderately expensive
- Requires maintenance
- May need to be seasonally removed, at least partly
- Drilling pipe for walkways requires heavy machinery and may be difficult and destabilize banks
- Aesthetics - not natural structure





# Elevated Walkways: Bladensburg Waterfront Launch Photo 1





# Elevated Walkways: Bladensburg Waterfront Launch Photo 2





## Portages

Portages are land routes used to transport boats to and from a launch area or between access sites. Where dams or other obstructions interrupt a paddling route, portages can provide a direct, often less hazardous path from one water access point to another.

Portages can also serve as detours around difficult sections of water that paddlers choose not to run, and they may serve as navigable connections between lakes or other bodies of water, helping to create a continuous paddling route. While this chapter discusses designs for portages around dams, the information provided may be applicable to portages in each of these settings.



Materials

Variations and Specifications

Advantages / Disadvantages

Case Study





## Portages: Materials

- Portages can be simple routes, such as trails made of soil, gravel, or asphalt. They can also be built structures, such as staircases with chutes or slides. The materials used and amount of construction necessary will depend on circumstances at an individual site such as the shore configuration, frequency of usage, dam ownership and available funds.
- Signage is crucial to making a portage visible to paddlers and for informing them about potential hazards on the water. Regardless of their visibility from the water, portages should be clearly marked in order to provide paddlers with sufficient time to reach the shore and take out. Clear and appropriate signage should discourage paddlers from attempting to clear a low head dam or spillway.



**Cheoah River Roadside Portage**  
**Alcoa Power Generating Inc.**



**Signage example from New River**  
**Trail State Park**





## Portages: Regulations

- Some dam owners have installed signage to educate paddlers about potential dangers. Dams for hydropower use may be required to have signage. The Federal Energy Regulatory Commission (FERC) provides regulatory oversight at hydropower dams to help develop and maintain a low hazard environment for the public, and considers designated and well-marked portages to be crucial communications tools to inform paddlers portaging around, putting in, or taking out at a hydropower dam.
- Licensing requirements issued by FERC require hydropower applicants to review recreational needs in the areas around their facilities. Licensees must assess and update the capacity of their public recreational facilities during the term of the license.
- For further information on the relationship between hydropower licensing and recreational use and liability, see:

[“Hydropower Relicensing and Recreational Liability”](#)





# Portages: Variations and Specifications

- According to [\*FERC Guidelines for Public Safety at Hydropower Projects\*](#), a portage should not be located within 300 feet of a dam, spillway, or powerhouse.
- The following general recommendations for portage areas are gathered from several sources, including an April 2003 assessment of the Trinity River in Texas.
- An effective Portage should include:
  - Clear, well-marked signage allowing paddlers sufficient time to reach shore before the take-out
  - A path at least 2' wide around the dam, with a slope no steeper than a 1:3
  - An accessible portage featuring a slope that does not exceed 8.33% or 1:12
  - At least 8' overhead clearance on the path and 4' to 8' clearance on either side
  - A vertical distance of 12" or less between the height of a boat and shore
  - A route that minimizes the distance that paddlers must carry their boats
  - Access points located on inside bends or areas of calm water
  - A backup or second path downstream from the portage access point upstream from a dam, when possible, giving paddlers an additional second opportunity area to take out.







## Portages: Advantages

### Advantages

- Provides defined and safe routes around dams and other structures that can be obstacles for paddlers, as long as they are well located and clearly marked
- Enables paddlers to navigate a somewhat continuous route along a water trail
- Gives paddlers designated routes to transport their boats between parking areas and launch sites
- May prevent damage to riparian or other sensitive areas by directing paddlers to a designated route



Portage that requires only occasional maintenance





## Portages: Disadvantages

### Disadvantages

- May not be easy for paddlers to manage while transporting their boats, if portages have a steep slope, uneven surface, or limited space
- May not provide paddlers with sufficient time or space to take out, especially if currents or winds are strong, if portage is located immediately upstream of a dam or other obstruction
- May be difficult to locate or access if not clearly marked



**An extremely low maintenance and rather tough portage to navigate!**





# Portages Case Study: Pejepscot River Access

Pejepscot River Access, Androscoggin River, Lisbon Falls-  
Brunswick, Maine



Pejepscot Dam, Androscoggin River, Maine





## Portages Case Study: Pejepscot River Access

**Problem:** One of the largest rivers in Maine, the Androscoggin hosts 28 dams along its 170 river miles. Not all of the dams have navigable routes around them; some require excessively long portages or do not provide portage trails at all. Other dams have portage trails that provide access both upstream and downstream. Most portage trails are marked with signs, however dam warnings are not easily visible on all sections of the river.

**Solution:** The Pejepscot River Access, downstream of Lisbon Falls, offers a solution to launching from a steep, rocky, and unstable shoreline where boulders, rock fragments, and fallen tree limbs make river access a challenge. Takeout occurs just above the dam, and a short portage through the woods connects paddlers with access just below the dam. A metal staircase, with a handrail on one side and a carpet-covered wooden slide on the other, enables paddlers to easily maneuver their boats down to the water. The carpet provides traction and helps to protect boat bottoms from damage. The staircase leads to a rocky, but sturdy and level launch area at the water's edge.





# Portages Case Study: Pejepscot River Access Photos



**Steel canoe portage stairway with padded canoe slide in place to allow canoes/kayaks to be slid down to the river for launching**

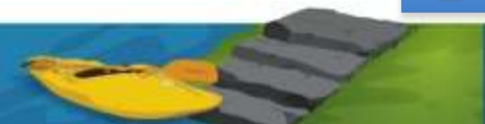



## Resources – Chapter 3

- [Guidelines for Developing Non-Motorized Boat Launches in Florida](#) – Florida Fish & Wildlife Conservation Commission
- [Iowa Watertrails Toolkit](#) – Iowa DNR
- [Construction Site Best Management Practices Manual](#) – State of California Department of Transportation
- [Wetland Trail Design and Construction](#) – US Forest Service
- [Environmental and Aesthetic Impacts of Small Docks and Piers](#) – NOAA Coastal Ocean Program
- Minnesota Division of State Parks
- [Floating Trail Bridges and Docks](#) – US Forest Service
- [Best Management Practices for Treated Wood](#) - Western Wood Preservers Institute
- [Streambank Revegetation and Protection: A Guide for Alaska](#) – AK Department of Fish & Game
- [Hydropower Relicensing, Recreational Liability, and Access](#) – American Whitewater
- [Guidelines for Public Safety at Hydropower Projects](#) – Federal Energy Regulatory Commission





## Photo Credits – Chapter 3

Slide 106: Courtesy of the National Park Service

Slide 107: Courtesy of the National Park Service

Slide 108: Courtesy of the National Park Service

Slide 109: Courtesy of the National Park Service

Slide 110: <http://www.greatfallsinformation.com/smithriver/>

Slide 111: <http://rotj.wordpress.com/category/james-river/kayaking-james-river/>

Slide 112: Courtesy of the National Park Service

Slide 113: Courtesy of the National Park Service

Slide 114: Courtesy of the National Park Service

Slide 115: Courtesy of the National Park Service

Slide 116: Left image - <http://www.nilex.com/book/export/html/24>

Slide 116: Right image - <http://www.adfg.alaska.gov/index.cfm?adfg=fishingSportAnglerAccessSouthcentral.sportsmansLodge>

Slide 117: <http://www.nilex.com/book/export/html/24>

Slide 119: <http://www.conteches.com/knowledge-center/pdh-credits/pdh-article-series/geosynthetics-in-articulating-concrete-block.aspx>

Slide 123: Jordan Loran, Maryland Dept. of Natural Resources

Slide 124: Jordan Loran, Maryland Dept. of Natural Resources

Slide 125: <http://outdoornebraska.ne.gov/blogs/2012/05/project-updates/>

Slide 127: [http://www.armortec.com/pages/Applications/Apps\\_boatramps.html](http://www.armortec.com/pages/Applications/Apps_boatramps.html)

Slide 128: [http://www.diamondjglobal.com/ProductsSolutions/45in\(1185cm\)ArticulatedConcreteMats.aspx](http://www.diamondjglobal.com/ProductsSolutions/45in(1185cm)ArticulatedConcreteMats.aspx)

Slide 130: <http://www.calumetindustries.com/?s=mats>

Slide 132: Courtesy of the National Park Service

Slide 133: Courtesy of the National Park Service





## Photo Credits – Chapter 3, cont.

Slide 134: Courtesy of the National Park Service

Slide 136: Courtesy of the National Park Service

Slide 137: Courtesy of the National Park Service

Slide 138: Nate Hoogeveen – Iowa DNR

Slide 139: Courtesy of the National Park Service

Slide 140: Courtesy of the National Park Service

Slide 141: Courtesy of the National Park Service

Slide 142: Courtesy of the National Park Service

Slide 143: Courtesy of the National Park Service

Slide 144: Courtesy of the National Park Service

Slide 145: Left image – Courtesy of the National Park Service

Slide 145: Right image - <http://forums.pondboss.com/ubbthreads.php?ubb=showflat&Number=2063>

Slide 147: Courtesy of the National Park Service

Slide 151: Courtesy of the National Park Service

Slide 152: Flickr

Slide 156: Courtesy of the National Park Service

Slide 158: Courtesy of the National Park Service

Slide 159: Courtesy of the National Park Service

Slide 160: <http://www.sunjournal.com/news/franklin/2012/09/02/two-new-hand-carry-boat-launch-sites-sandy-river-n/1245437>

Slide 161: Courtesy of the National Park Service

Slide 162: Courtesy of the National Park Service

Slide 165: Courtesy of the National Park Service

Slide 166: Courtesy of the National Park Service







## Photo Credits – Chapter 3, cont.

Slide 167: Courtesy of the National Park Service

Slide 168: Courtesy of the National Park Service

Slide 174: Courtesy of the National Park Service

Slide 175: <http://www.palmbeachpost.com/news/news/snook-islands-fish-pier-boardwalk-set-to-open-in-l/nL34g/>

Slide 176: Left image - <http://kayakdave.com/2012/09/12/how-to-launch-from-a-dock-video/>

Slide 176: Right image - <http://seawatch-nc.com/blog/?tag=southport>

Slide 179: <http://www.metrojacksonville.com/forum/index.php?topic=15117.0>

Slide 181: Courtesy of the National Park Service

Slide 182: Courtesy of the National Park Service

Slide 183: [http://www.geocities.ws/dock\\_king/](http://www.geocities.ws/dock_king/)

Slide 184: <http://www.nachi.org/deck-inspections.htm>

Slide 185: <http://eliteconstructionandlandscaping.com/dock.htm>

Slide 187: Minnesota Division of State Parks

Slide 188: Minnesota Division of State Parks

Slide 189: Minnesota Division of State Parks

Slide 191: <http://www.marina-products.com/default.asp?PageIndex=78>

Slide 193: <http://www.modudock.com/>

Slide 194: <http://www.chesapeake dock.com/services-floatingdocks.cfm>

Slide 195: Courtesy of the National Park Service

Slide 196: [http://www.hdpeinc.com/floating\\_docks.html](http://www.hdpeinc.com/floating_docks.html)

Slide 203: Maryland Department of Natural Resources

Slide 204: Maryland Department of Natural Resources

Slide 207: Courtesy of the National Park Service





## Photo Credits – Chapter 3, cont.

Slide 208: Courtesy of the National Park Service

Slide 209: Courtesy of the National Park Service

Slide 210: Courtesy of the National Park Service

Slide 211: Courtesy of the National Park Service

Slide 212: Courtesy of the National Park Service

Slide 213: M-NCPPC/Cassi Hayden - [http://www.mncppc.org/commission\\_home.html](http://www.mncppc.org/commission_home.html)

Slide 214: M-NCPPC/Cassi Hayden - [http://www.mncppc.org/commission\\_home.html](http://www.mncppc.org/commission_home.html)

Slide 215: Left image - <http://www.wickcraft.com/PierSystems.aspx>

Slide 215: Right image - <http://walkacrossvirginia.blogspot.com/2012/05/day-11-12-dam-portages-above-lynchburg.html>

Slide 216: M-NCPPC/Cassi Hayden - [http://www.mncppc.org/commission\\_home.html](http://www.mncppc.org/commission_home.html)

Slide 217: M-NCPPC/Cassi Hayden - [http://www.mncppc.org/commission\\_home.html](http://www.mncppc.org/commission_home.html)

Slide 218: <http://www.bestkayakdocks.com/>

Slide 220: M-NCPPC/Cassi Hayden - [http://www.mncppc.org/commission\\_home.html](http://www.mncppc.org/commission_home.html)

Slide 221: M-NCPPC/Cassi Hayden - [http://www.mncppc.org/commission\\_home.html](http://www.mncppc.org/commission_home.html)

Slide 222: <http://walkacrossvirginia.blogspot.com/2012/05/day-11-12-dam-portages-above-lynchburg.html>

Slide 223: Left image: Marshall L. Olson and Oliver L. Ammons presentation: Through Paddling on the Little TN River

Slide 223: Right image: New River Trail State Park - [Mark.Hufeisen@dcr.virginia.gov](mailto:Mark.Hufeisen@dcr.virginia.gov)

Slide 226: Lelia Mellen, National Park Service

Slide 227: Lelia Mellen, National Park Service

Slide 228: Flickr

Slide 229: Left image – Courtesy of the National Park Service

Slide 229: Right image - <http://www.brunswickme.org/departments/parks-recreation/parks-facilities/parks-natural-areas/>

